

Technical sheet :

100 VJR



Capacities		Metric	Imperial
Working height	h21	9.85 m	32 ft 4 in
Platform height	h7	7.85 m	25 ft 9 in
Max. outreach	r1	3.15 m	10 ft 4 in
Overhang	h31	6.67 m	21 ft 11 in
Pendular arm rotation (bottom)		+70 °	+70 °
Platform capacity	Q	200 kg	441 lbs
Turret rotation		350 °	350 °
Number of people (inside / outside)		2 / 1	2 / 1
Weight and dimensions			
Platform weight*		2650 kg	5842 lbs
Platform dimensions (length x width)	lp / ep	1.11 m x 0.93 m	3 ft 8 in x 3 ft 1 in
Overall width	b1	0.99 m	3 ft 3 in
Overall length	l1	2.8 m	9 ft 2 in
Overall height	h17	1.99 m	6 ft 6 in
Floor height (access)	h20	0.51 m	1 ft 8 in
Jib length	l13	1.5 m	4 ft 11 in
Counterweight offset (turret at 90°)	a7	0.095 m	4 in
Internal turning radius (over tyres)	b13	0.59 m	1 ft 11 in
External turning radius	Wa3	2.09 m	6 ft 10 in
Plugs / stability bars ground clearance	m6	0.02 m	1 in
Ground clearance at centre of wheelbase	m2	0.09 m	4 in
Wheelbase	y	1.2 m	3 ft 11 in
Performances			
Drive speed - stowed		5 km/h	3.1 mph
Drive speed - raised		0.7 km/h	0.4 mph
Gradeability		25 %	25 %
Permissible leveling		2 °	2 °
Wheels			
Tyres type		Solid non-marking tires	Solid non-marking tires
Dimensions of front wheels / rear wheels		0.41 x 0.13m - 0.41 x 0.13m	0.41 x 0.13m - 0.41 x 0.13m
Drive wheels (front / rear)		0 / 2	0 / 2
Steering wheels (front / rear)		2 / 0	2 / 0
Braking wheels (front / rear)		0 / 2	0 / 2
Engine/Battery			
Electric engine power rating		2 x 1.5 kW	2 x 1.5 kW
Number of hydraulic pump / Capacity of hydraulic pump		2 x 4.20 cm³	2 x 0.26 in³
Battery / Batteries capacity		24 V / 250 Ah	24 V / 250 Ah
Integrated charger (V / Ah)		24 V / 30 Ah	24 V / 30 Ah
Miscellaneous			
Number of cycles with STD Battery (HIRD)		29	29
Ground Pressure		11.8 daN/cm²	171.14 PSI
Hydraulic Pressure		140 Bar	10 PSI
Hydraulic tank capacity		22 l	5.81 US gal
Vibration on hands/arms		< 2.5 m/s	< 8.2 ft/s
Standards compliance			
This machine is in compliance with:		European directives: 2006/42/EC- Machinery (revised EN280:2013) - 2004/108/EC (EMC) - 2006/95/EC (Low voltage)	European directives: 2006/42/EC- Machinery (revised EN280:2013) - 2004/108/EC (EMC) - 2006/95/EC (Low voltage)

*Varies according to options and standards of the country to which the machine is delivered

Load chart

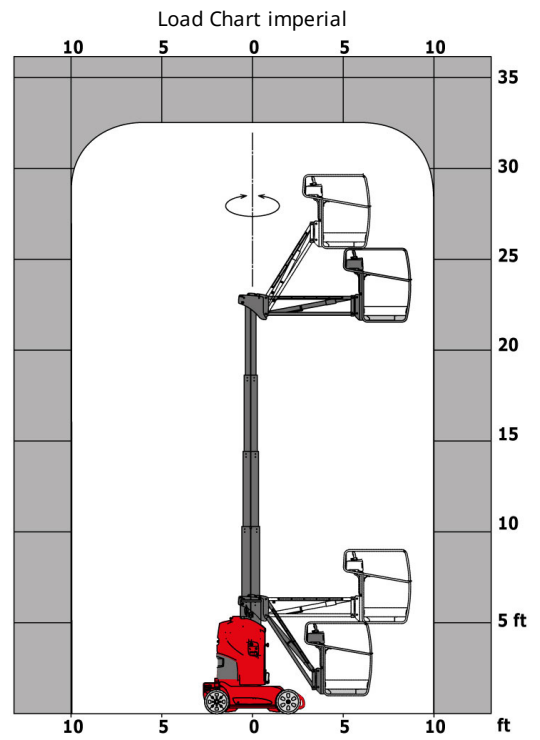
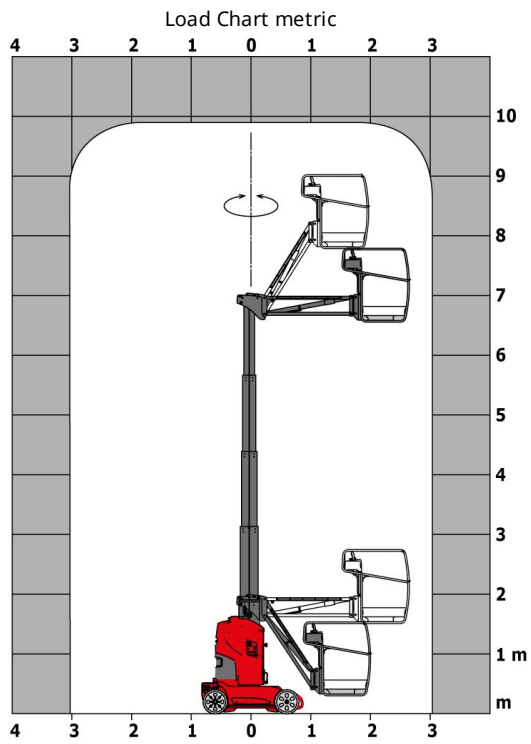

Dimensional drawing

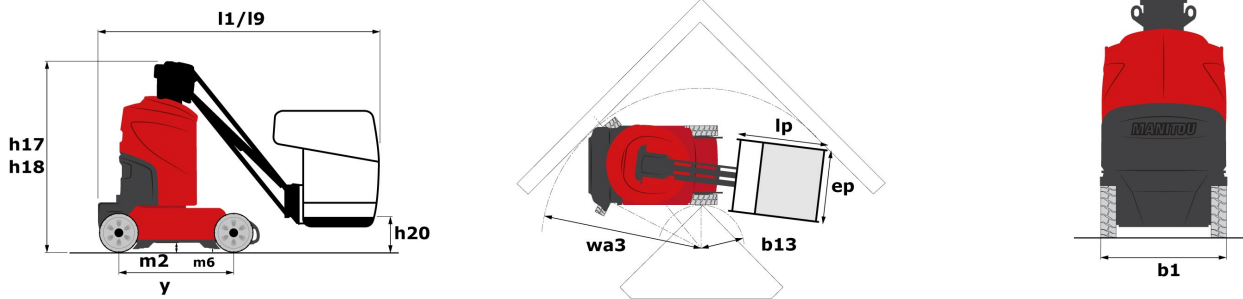

Equipment

Standard

- Audible alarm and illuminated indicator lamp (leveling, overload, lowering)
- Battery charge indicator lamp
- CAN bus technology
- Emergency stop button in platform and on frame
- Fixed pothole protection
- Fork pockets
- Horn in the platform
- Hour meter
- Integrated diagnostic assistance
- Manual emergency lowering
- Multi-voltage integrated charger
- Negative-type braking on rear wheels
- Non-marking rubber tyres
- Pendular arm
- Platform with open-work floor
- Proportional controls
- Slings and securing rings
- Tool box in platform
- Traction battery

Optional

- 110 or 230V plug with differential circuit breaker
- 230V Predisposition
- Air predisposition
- Beep on every movement
- Biodegradable oil
- Centralized recharging of battery
- Extreme cold oil
- Flashing Light
- Maintenance-free battery
- Personalized paintwork
- SMS : Safe Man System
- Safety harness
- Working headlight in platform

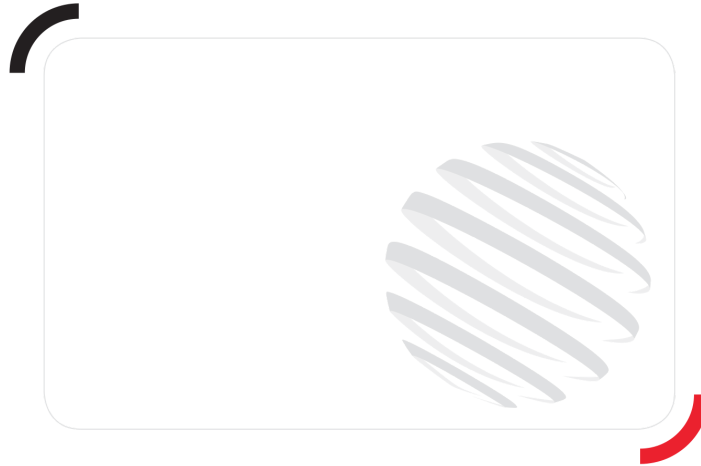

Siège Social
430 rue de l'Aubinière - 44150 Ancenis Cedex - France
Tel: +33(0)2 40 09 10 11 - Fax: +33 (0)2 40 09 10 97
www.manitou.com



This brochure describes versions and configuration options for Manitou products which may be fitted with different equipment. The equipment described in this brochure may be standard, optional or not available depending on version. Manitou reserves the right to change the specifications shown and described at any time and without prior warning. The manufacturer is not liable for the specifications given. For more information, contact your Manitou dealer. Non-contractual document. Product descriptions may differ from actual products. List of specifications is not comprehensive. The logos and visual identity of the company are the property of Manitou and may not be used without authorisation. All rights reserved. The photos and diagrams contained in this brochure are provided for information only.

MANITOU BF SA - Limited company with board of directors - Share capital: 39,668,399 euros - 857 802 508
RCS Nantes